

IT/EN



ATHENA

Servoscala a piattaforma
Platform stairlift



SOLUZIONI PERSONALIZZATE PER L'ABBATTIMENTO
DELLE BARRIERE ARCHITETTONICHE
CUSTOMISED SOLUTIONS FOR REMOVAL
OF ARCHITECTURAL BARRIERS

Il servoscala portacarrozze ATHENA è ideale per superare scale e rampe rettilinee, senza variazioni di pendenza.

The ATHENA platform stairlift is ideal for traversing straight stairs and ramps of uniform slope.

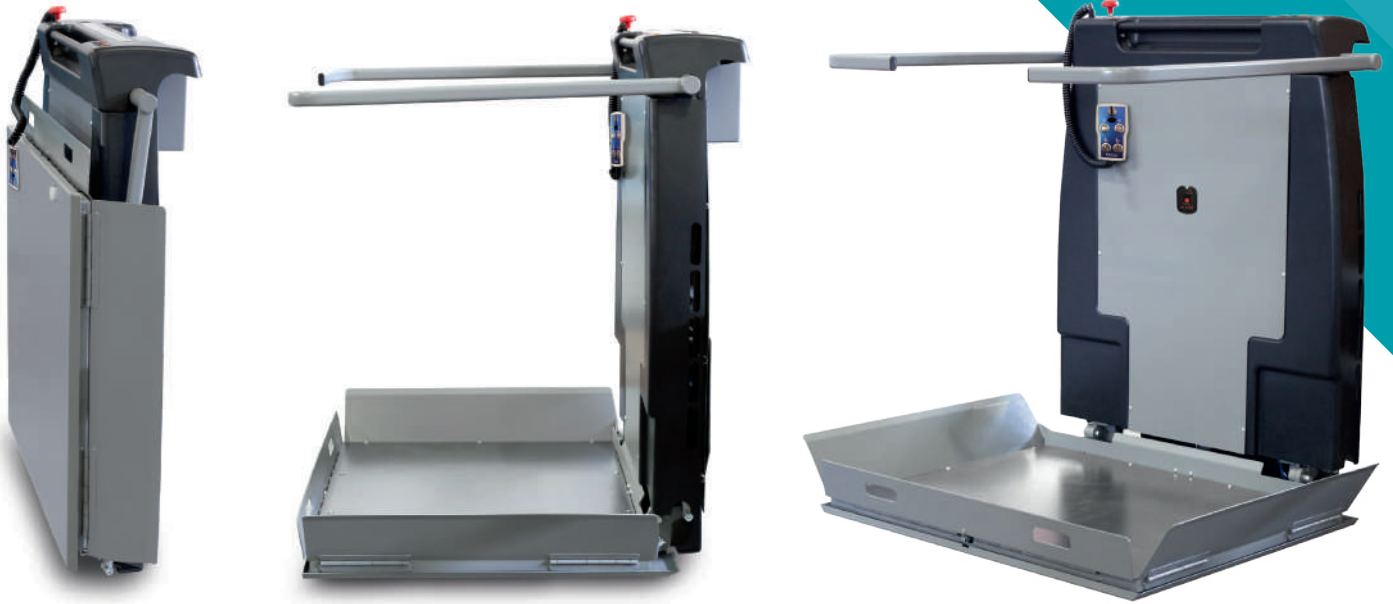

La più stretta sul mercato anche con piedi solo 320mm da parete o ringhiera retrostante.

The narrowest on the market, at only 320mm from the stairway wall or railing, including mounting feet.

Opzionale:

- Strapuntino per seduta
- Pedana maggiorata

Optional:

- Folding seat
- Oversized platform

1

PRATICITÀ E SICUREZZA PRACTICALITY AND SAFETY

ATHENA offre praticità e sicurezza. La pulsantiera con cavo estensibile è inclusa, agevolando utenti e accompagnatori. Le due barre di contenimento, motorizzate, garantiscono protezione in ogni posizione.

ATHENA offers convenience and safety. The included control-button strip with extendable cable is suited for both users and accompanying persons. The two motorised containment bars ensure protection in every direction.

3

ACCESSORI COMPLETI COMPLETE RANGE OF ACCESSORIES

L'impianto dispone di numerosi optional, come la pedana motorizzata e barre retrattili. Trattamenti speciali proteggono il servoscala dagli agenti atmosferici, rendendolo idoneo anche all'esterno.

The system has numerous options, among which the platform with motorised folding and retractable bars. Special treatments provide protection from the elements, enabling outdoor installation.

2

DESIGN INNOVATIVO E COMPATTEZZA COMPACT, WITH INNOVATIVE DESIGN

ATHENA si distingue per il design innovativo e la compattezza. Il servoscala è silenzioso durante il movimento, offrendo comfort acustico.

ATHENA is remarkably compact and features innovative design. The stairlift operates silently, avoiding disturbing noise.

4

FACILITÀ DI INSTALLAZIONE E GARANZIA EASE OF INSTALLATION AND WARRANTY

L'impianto reversibile consente di installarlo sia sul lato destro che sinistro della scala, con rotaie modulari in alluminio anodizzato per ambienti marini. Non richiede opere murarie aggiuntive né permessi di installazione. Dotato di dispositivi di sicurezza, ATHENA è personalizzabile e coperto da garanzia Faboc di 24 mesi.

The reversible installation system, with modular anodised aluminium rails classified for marine environments, allows placement on either the right or left side of the staircase. No masonry work or installation permits are required. Equipped with safety devices, ATHENA is customisable and covered by Faboc's 24-month warranty.

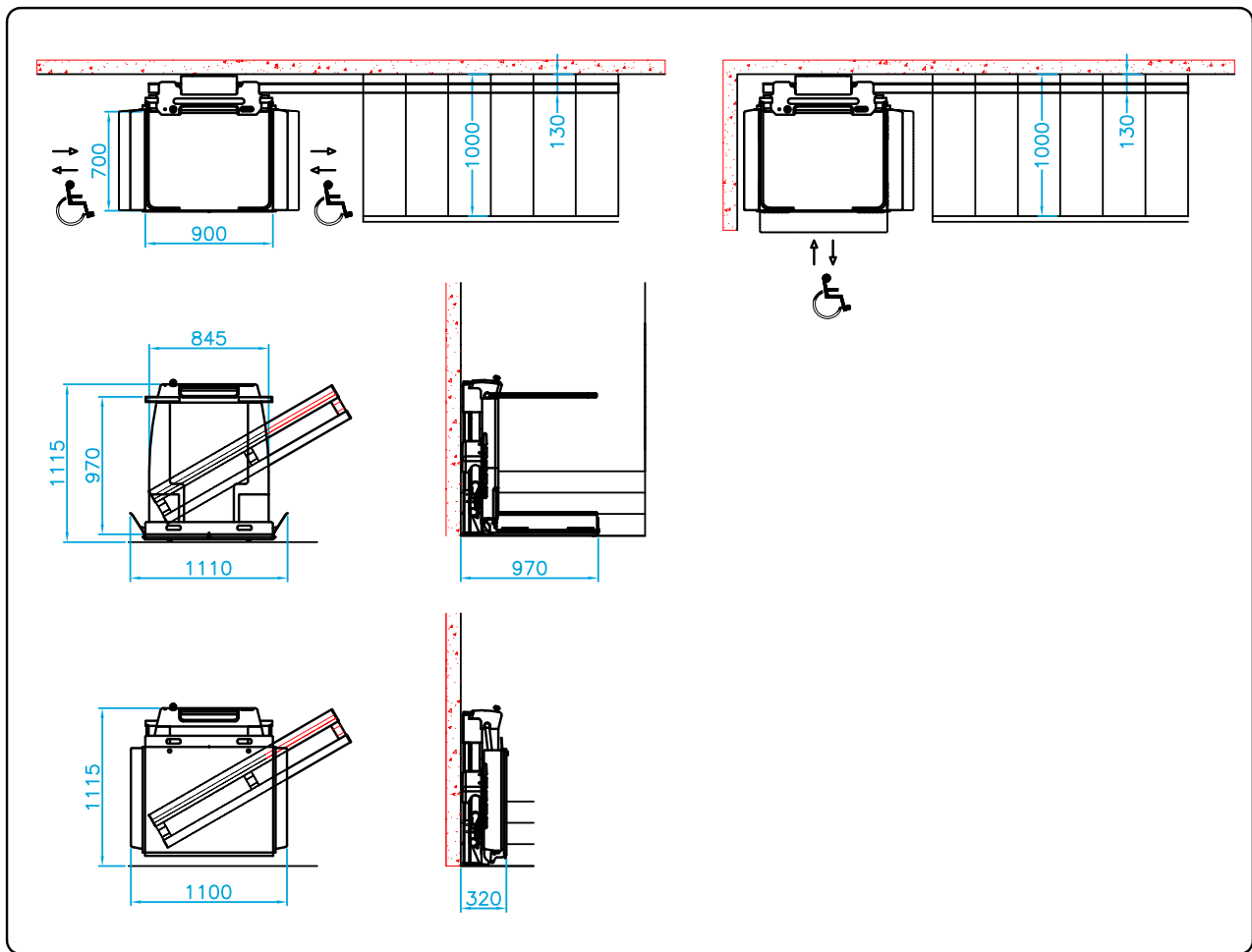

Portata: 250 Kg - inclinazione massima 45°

Velocità massima: 6 m/min

Pedana ribaltabile motorizzata

Due bandelle motorizzate per il contenimento e il raccordo ai piani

Due barre di protezione motorizzate e richiudibili all'interno della pedana

Pulsantiera a bordo macchina con cavo estensibile

Pulsantiere di piano con funzionamento a radiocomando

Alimentazione 24VCC con batterie antiblackout e carica batterie automatico alle estremità

Motore autofrenante 600W 24VDC

Traino con pignone dentato e riduttore irreversibile su cremagliera fissata alla parte inferiore della rotaia

Paracadute azionato da limitatore di velocità secondo norme EN 81/40

Sistemi antischiacciamento, anticesoiamento e antiurto secondo norme EN 81/40

Dispositivo di comunicazione vocale bidirezionale secondo norme EN 81/40

Fissaggio rotaia con piedi su gradini portanti o attacchi a parete portante

Colori standard: macchina RAL 7037 con finiture in ABS nero - Rotaia alluminio anodizzato argento e piedi RAL 7037

Load capacity: 250 kg - Maximum inclination 45°

Maximum speed: 6 m/min

Motorised folding platform

Two motorised side-bands for containment and connection at floor levels

Two motorised lockable protection bars inside the platform

On-board control-button strip with extendable cable

Radio-control-button strip at floor level

24 VDC power supply with anti-blackout batteries and automatic battery charger at stairway top and bottom

Self-braking motor, 600W, 24VDC

Drive with toothed pinion and irreversible reduction gear on rack, fixed to the bottom of the rail

Overspeed-governor stopping system compliant with EN 81/40 standards

Anti-crushing, anti-shearing and anti-shock systems compliant with EN 81/40 standards

Two-way voice communication device compliant with EN 81/40 standards.

Footed attachment of the rail on load-bearing steps or attachments to load-bearing wall

Standard colours: machine in RAL 7037 with black ABS trim; rails in silver anodised aluminium; feet in RAL 7037



Gli impianti sono progettati e costruiti in conformità a quanto previsto da:

NORMATIVA EUROPEA EN 81-40

LEGGE N. 13 DEL 09/01/89. DECRETO MINISTERIALE N. 236 DEL 14/06/89
2006/42/CE (DIRETTIVA MACCHINE) recepita con d.lgs. n.17 del 27/01/2010,
2014/30/UE (COMPATIBILITA' E.M.C.) recepita con il Dlgs 80/16.
2014/35/UE (DIRETTIVA BASSA TENSIONE) recepita con il Dlgs 86/16

The systems have been designed and manufactured in accordance with:

PRODUCT STANDARD EN 81-40
MACHINE DIRECTIVE 2006/42/CE
ELECTROMAGNETIC COMPATIBILITY DIRECTIVE 2014/30/UE
LOW VOLTAGE DIRECTIVE 2014/35/UE



SOLUZIONI PERSONALIZZATE

CUSTOMISED SOLUTIONS

ATHENA è idoneo sia all'uso in edifici privati che pubblici. È idoneo anche nell'adempimento degli obblighi previsti, in caso di nuova realizzazione o ristrutturazione, dalla Legge 13 del 09/01/89 e D.M. 236 del 14/06/89 relativa all'abbattimento delle barriere architettoniche in condomini, alberghi, ristoranti, bar, negozi, uffici e altri locali con accesso al pubblico.

ATHENA is suitable for use in both private and public buildings. It is also suitable for new constructions or renovations, to remove architectural barriers in condominiums, hotels, restaurants, bars, shops, offices and other premises with public access.

DETTAGLI

DETAILS



GAMMA PRODOTTI FABOC

FABOC PRODUCT RANGE

Montascale / Stair lift

Servoscala / Platform stairlift



VICTORIA



ATHENA



OLYMPIA

Piattaforme elevatrici / Lifting platforms



X-SLIM

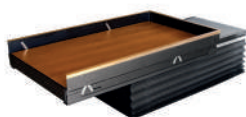

Z-SLIM



ONESTEP



PARIGI-A



Faboc Due srl

Via della Steccaia, 34C - Loc. Badia Elmi
53037 San Gimignano (SI) ITALIA



+39 0577 1489094



info@fabocdue.com



www.fabocdue.com

AGENTE DI ZONA
AREA AGENTS